



E-KABIN X SERIES

STAINLESS STEEL ENCLOSURES

www.eaelektrotechnik.com

CONTENTS

XS MODULAR INDOOR FLOOR STANDING ENCLOSURES	04
XH MODULAR OUTDOOR FLOOR STANDING ENCLOSURES	08
XM MONOBLOCK ENCLOSURES	12
XT TERMINAL BOXES	20
XK CONSOLES	24
CUSTOM DESIGN	28
WHITE PAPER	29

XS SERIES OVERVIEW



XS Series Stainless Steel, Modular, Indoor, Floor Standing Enclosures

E-Kabin XS Series modular floor standing enclosures are designed for general purpose indoor electrical applications. Their simple design provides functionality for different usage and economy. They have an extensible structure for stand-alone applications or for multiple combinations.

Place of use	: Indoor
Protection class	: IP55, IP41 – Depending on the front door type
Operating temperature	: -5°C, +40°C
Operating relative humidity	: 90% at +20°C 50% at +40°C
Operating environment conditions class	: IE33 but, max. relative humidity %90 and min. temperature -5°C - Acc. to EN 60721-3-3
Standards	: IEC 61439-1 IEC 62208 IEC 60529 IEC 62262
Material	: 304 grade stainless steel - standard 316 grade stainless steel - optional

XS SERIES CHARACTERISTICS



Clean and Smooth Surface

Production process is free from welded stud marks. In this way clean and smooth surface appearance is provided.



IP55 Gasket Protection

Foam-in-place gasket behind the door does not lose its elasticity in time and provides protection against dust and water.



Optional Stainless Steel Lock

Standard lock is swing handle type and made of special plastic material which provides high chemical resistance. Optionally, 316 grade stainless steel lock is available.

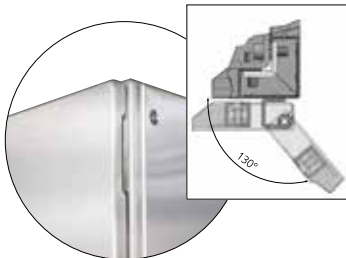

Robust Hidden Hinge

Door hinge which is 3mm thick and 316 grade stainless steel, is designed in such a way that it is not visible from outside of the door. Thanks to this hinge the door can be opened up to 130°.



E-Kabin Interior Accessories

All E-Kabin interior accessories can also be used in stainless steel products.



Modular Plinth

It's possible to increase enclosure height by mounting one more extra modular plinth on top of existing one.

XS SERIES DIMENSIONS

XS SERIES DIMENSIONS		
HEIGHT	WIDTH	DEPTH
1400	400	400
1600	500	500
1800	600	600
2000	700	700
2200	800	800

304 / 316

304 grade stainless steel is standard.
Optionally, 316 grade stainless steel is available.

INOX / PLASTIC LOCK

Standard lock is plastic. Optionally 316 or 304 grade stainless steel lock is available.

E-KABIN INTERIOR ACCESSORIES

All E-Kabin interior accessories can also be used in stainless steel products.

MODIFIED DESIGN

Modification possibilities on standard design.

- Different dimensions
- Different material thickness
- Hole processing

ADDITIONAL POWDER COATING

Optional, powder coating in any desired RAL colour codes or lacquer coating

XS SERIES DIMENSIONS

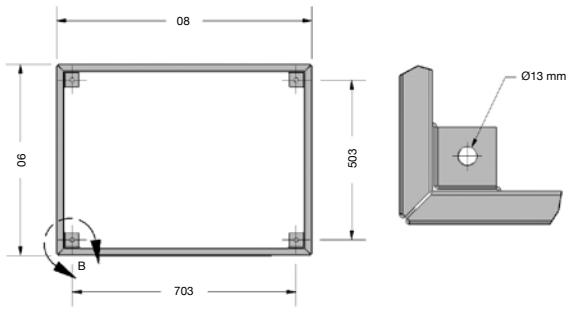
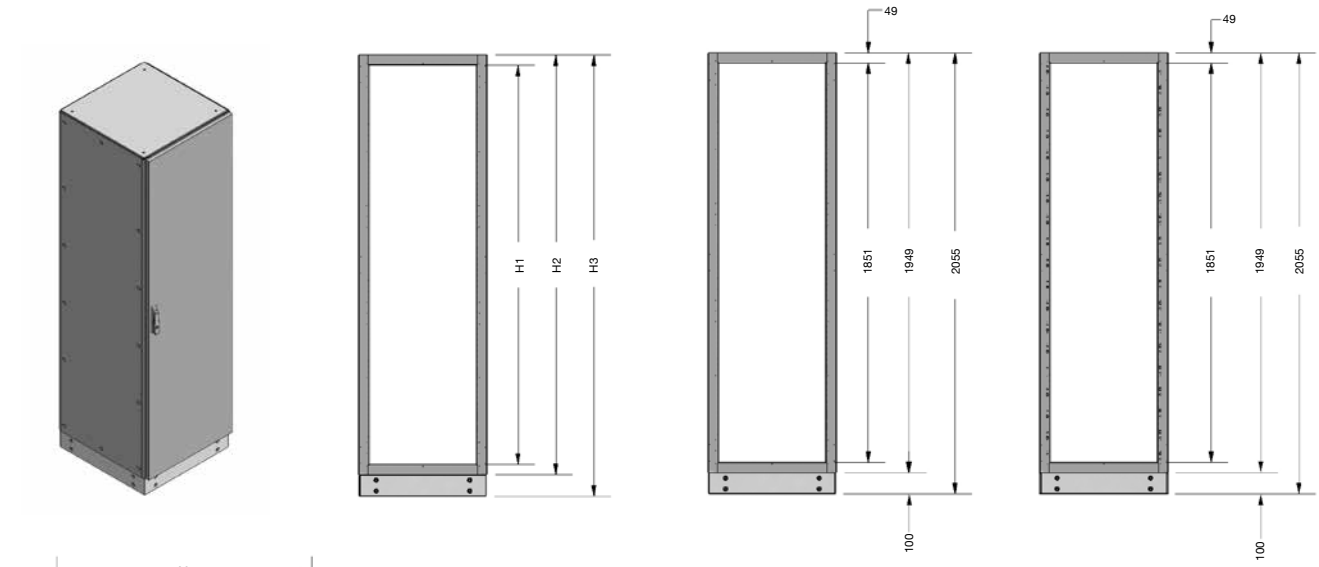

Net Dimensions	Enclosure rated height		
	18	20	22
H1	1749 mm	1949 mm	2149 mm
H2	1651 mm	1851 mm	2051 mm
H3	1855 mm	2055 mm	2255 mm

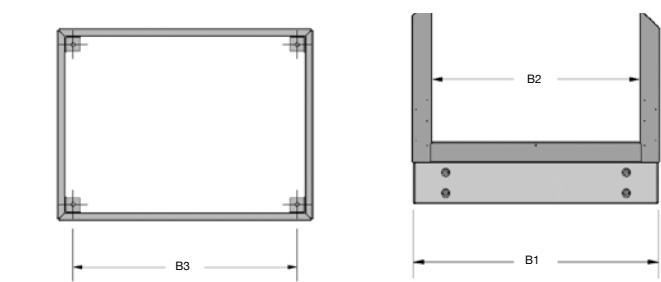

Net Dimensions	Enclosure rated width or depth				
	04	05	06	07	08
B1	396 mm	496 mm	596 mm	696 mm	796 mm
B2	301 mm	401 mm	501 mm	601 mm	701 mm
B3	303 mm	403 mm	503 mm	603 mm	703 mm

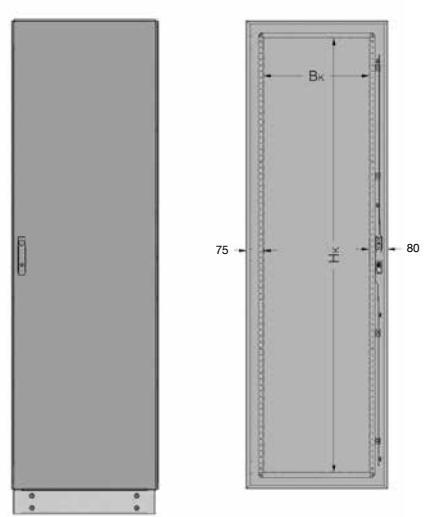

Front door usable net height (H_κ)

	ES OK 18	ES OK 20	ES OK 22
Net Height (H _κ)	1610 mm	1810 mm	2010 mm

Front door usable net width (B_κ)

	03	04	05	06	07	08
Net Width (B _κ)	145 mm	245 mm	345 mm	445 mm	545 mm	645 mm

XH SERIES OVERVIEW



XH Series Stainless Steel Modular Floor Standing Outdoor Enclosures

E-Kabin XH Series Electrical Enclosures are designed for general purpose outdoor electrical applications. They have an extensible structure for stand-alone applications or for multiple combinations.

Place of use	: Outdoor
Protection class	: IP55, IP41 – Depending on the front door type
Operating temperature	: -5°C, +40°C
Operating relative humidity	: 90% at +20°C 50% at +40°C
Operating environment conditions class	: IE37 but, max. Relative humidity %90 and min. temperature -5°C / according to -EN60721 - 3 - 3 -
Standards	: IEC 61439-1 IEC 62208 IEC 60529 IEC 62262
Material	: 304 grade stainless steel - standard 316 grad stainless steel - optional
Lock Set	: Plastic – Standard Stainless steel – Optional

XH SERIES CHARACTERISTICS



Aesthetic Look

Modern exterior outlines, internally accessible side and back panel connections combined with clean surface treatment, provide aesthetic appearance.



Modular Design-side-by-side expandability

Thanks to modular design of framework and roof, expanding side by side is possible to form large combinations.



Optional Eyebolts

Optional eyebolts enable fully loaded enclosure to be lifted up and carried for installation purposes.



IP55 Gasket Protection

Foam-in-place gasket behind the door does not lose its elasticity in time and provides protection against dust and water.



Under Canopy Fan Unit

A fan unit can be installed under the canopy. It is easily accessible from inside the enclosure for service and maintenance.



Optional Stainless Steel Lock

Standard lock is swing handle type and made of special plastic material which provides high chemical resistance. Optionally, 316 grade stainless steel lock is available.

XH SERIES DIMENSIONS

ENCLOSURE RATED HEIGHT	A DIMENSION FRAMEWORK HEIGHT	B DIMENSION EXTERNAL HEIGHT (A+180 mm)
14-1400	1350	1530
16-1600	1550	1730
18-1800	1750	1930
20-2000	1950	2130
22-2200	2150	2330

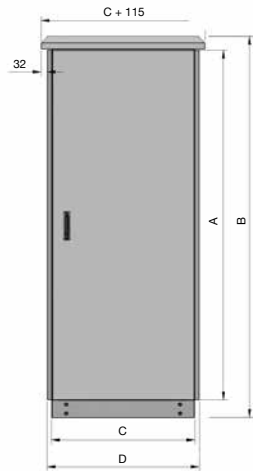

ENCLOSURE RATED WIDTH	C DIMENSION FRAMEWORK WIDTH	D DIMENSION ENCLOSURE WIDTH SIDE COVERS INCLUDED (C+50 mm)
04-400 mm	400	450
05-500 mm	500	550
06-600 mm	600	650
08-800 mm	800	850
10-1000 mm	1000	1050
12-1200 mm	1200	1250

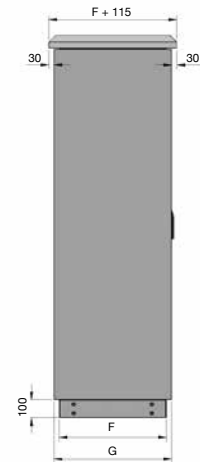

ENCLOSURE RATED DEPTH	F DIMENSION BODY DEPTH	G DIMENSION ENCLOSURE DEPTH FRONT-REAR COVERS INCLUDED (F+55 mm)
04-400 mm	400	455
05-500 mm	500	555
06-600 mm	600	655
08-800 mm	800	855

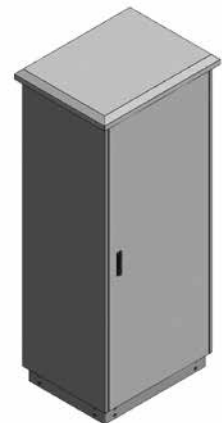

XH SERIES DIMENSIONS

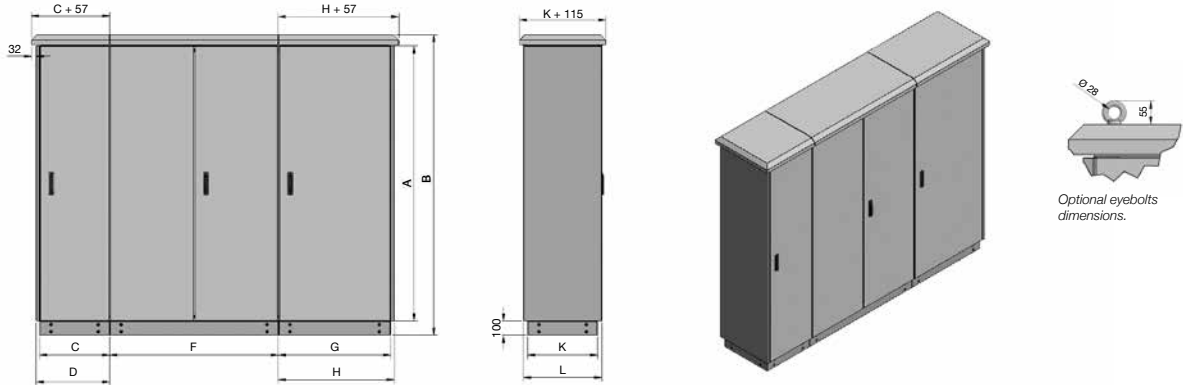

Side Enclosure

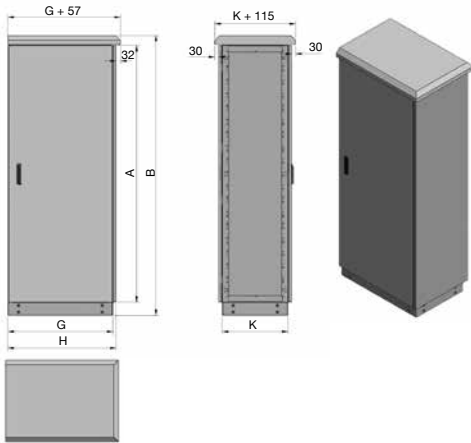

Middle Enclosure

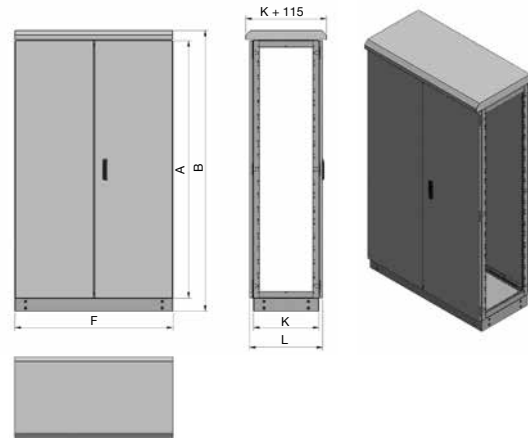

ENCLOSURE RATED HEIGHT	A FRAMEWORK HEIGHT	B EXTERNAL HEIGHT (A+180 mm)
14-1400	1350	1530
16-1600	1550	1730
18-1800	1750	1930
20-2000	1950	2130
22-2200	2150	2330

ENCLOSURE RATED DEPTH	K FRAMEWORK DEPTH	L ENCLOSURE DEPTH (FRONT-REAR PANELS INCLUDED) (K+55 mm)
04-400 mm	400	455
05-500 mm	500	555
06-600 mm	600	655
08-800 mm	800	855

ENCLOSURE RATED WIDTH	C FRAMEWORK WIDTH	C ENCLOSURE WIDTH (SIDE PANELS INCLUDED) (C+25 mm)	F FRAMEWORK WIDTH	G FRAMEWORK WIDTH	H ENCLOSURE WIDTH (SIDE PANELS INCLUDED) (G+25 mm)
04-400 mm	400	425	400	400	425
05-500 mm	500	525	500	500	525
06-600 mm	600	625	600	600	625
08-800 mm	800	825	800	800	825
10-1000 mm	1000	1025	1000	1000	1025
12-1200 mm	1200	1225	1200	1200	1225

XM SERIES OVERVIEW



XM Series Stainless Steel Monoblock Enclosures

E-Kabin XM Series electrical enclosures are designed for general purpose electrical applications.

Place of use	: Indoor, Outdoor
Protection class	: IP 66
Type of mounting	: Wall-mounted
Operating temperature	: -5°C, +40°C
Operating relative humidity	: 90% at +20°C 50% at +40°C
Standards	: IEC 61439-1, IEC 62208 IEC 60529, IEC 62262
Operating environment conditions class	: IE37 but, max. relative humidity %90 and min. temperature -5°C according to -EN 60721 - 3 - 3 -
Material	: 304 grade stainless steel - standard 316 grade stainless steel - optional
Lock Set	: Plastic – Standard Stainless steel – Optional



XM SERIES CHARACTERISTICS

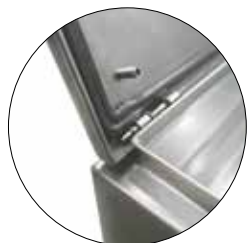

Polyurethane Gasket

Polyurethane foam-in-place gasket, does not lose its elasticity over time and provides protection against dust and water.

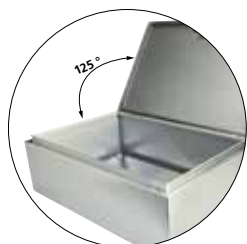

Hidden Hinge

Thanks to stainless steel hinge the door can be opened up to 125° angle. This feature provides comfortable access into the enclosure.



Optional Stainless Steel Bracket

Optional bracket set provides enclosure mounting on the wall to be done easily and quickly. Thanks to 90° swivel feature of the bracket, it's positioning can be chosen either horizontally or vertically.



Symmetrical Canopy

For outdoor applications, symmetrical canopy design provides an aesthetic look. They can only be used for floor standing applications. For symmetrical canopies wall mounting applications with bracket set are not suitable.



Asymmetrical Canopy

For wall mounting outdoor applications asymmetrical canopy can be used with brackets. Thanks to their reverse angle edge design above door threshold, rain water flows out of the enclosure.



Optional Stainless Steel Lock

Standard lock is quarter-turn 3 mm double-bit type and made of special plastic material which provides high chemical resistance. Overlapping door locks are swing handle type and similar to floor standing modular types. Optionally, 316 grade stainless steel lock is available.

XM SERIES ORDER INFORMATION

XM SERIES STAINLESS STEEL MONOBLOCK ENCLOSURES SINGLE DOOR					
HEIGHT (A)	WIDTH (B)	DEPTH (C)	ORDER CODES (304)	ORDER CODES (316)	NUMBER of LOCK
300	200	120	XM 30 20 12-304	XM 30 20 12-316	1
300	200	150	XM 30 20 15-304	XM 30 20 15-316	1
300	300	150	XM 30 30 15-304	XM 30 30 15-316	1
300	300	200	XM 30 30 20-304	XM 30 30 20-316	1
400	300	150	XM 40 30 15-304	XM 40 30 15-316	1
400	300	200	XM 40 30 20-304	XM 40 30 20-316	1
400	400	200	XM 40 40 20-304	XM 40 40 20-316	1
500	350	150	XM 50 35 15-304	XM 50 35 15-316	1
500	350	200	XM 50 35 20-304	XM 50 35 20-316	1
500	400	200	XM 50 40 20-304	XM 50 40 20-316	1
500	500	200	XM 50 50 20-304	XM 50 50 20-316	1
600	400	150	XM 60 40 15-304	XM 60 40 15-316	1
600	400	200	XM 60 40 20-304	XM 60 40 20-316	1
600	400	200	XM 60 40 25-304	XM 60 40 25-316	1
600	500	300	XM 60 50 30-304	XM 60 50 30-316	1
600	600	200	XM 60 60 20-304	XM 60 60 20-316	1
600	600	250	XM 60 60 25-304	XM 60 60 25-316	1
700	500	150	XM 70 50 15-304	XM 70 50 15-316	2
700	500	200	XM 70 50 20-304	XM 70 50 20-316	2
700	500	300	XM 70 50 30-304	XM 70 50 30-316	2
800	600	150	XM 80 60 15-304	XM 80 60 15-316	2
800	600	200	XM 80 60 20-304	XM 80 60 20-316	2
800	600	250	XM 80 60 25-304	XM 80 60 25-316	2
800	600	300	XM 80 60 30-304	XM 80 60 30-316	2
900	600	150	XM 90 60 15-304	XM 90 60 15-316	2
900	600	200	XM 90 60 20-304	XM 90 60 20-316	2
900	600	250	XM 90 60 25-304	XM 90 60 25-316	2
1000	600	200	XM 100 60 20-304	XM 100 60 20-316	2
1000	600	250	XM 100 60 25-304	XM 100 60 25-316	2
1000	600	300	XM 100 60 30-304	XM 100 60 30-316	2
1000	700	150	XM 100 70 15-304	XM 100 70 15-316	2
1000	700	200	XM 100 70 20-304	XM 100 70 20-316	2
1000	700	300	XM 100 70 30-304	XM 100 70 30-316	2
1000	700	400	XM 100 70 40-304	XM 100 70 40-316	2
1000	800	300	XM 100 80 30-304	XM 100 80 30-316	2
1000	800	400	XM 100 80 40-304	XM 100 80 40-316	2
1200	600	300	XM 120 60 30-304	XM 120 60 30-316	2
1200	800	150	XM 120 80 15-304	XM 120 80 15-316	2
1200	800	200	XM 120 80 20-304	XM 120 80 20-316	2
1200	800	300	XM 120 80 30-304	XM 120 80 30-316	2
1200	800	400	XM 120 80 40-304	XM 120 80 40-316	2

XM SERIES ORDER INFORMATION

XM SERIES STAINLESS STEEL MONOBLOCK ENCLOSURES OVERLAPPING DOOR				
HEIGHT (A)	WIDTH (B)	DEPTH (C)	ORDER CODES (304)	ORDER CODES (316)
800	1000	300	XM 80 100 30-304	XM 80 100 30-316
800	1200	300	XM 80 120 30-304	XM 80 120 30-316
1000	1000	300	XM 100 100 30-304	XM 100 100 30-316
1000	1200	300	XM 100 120 30-304	XM 100 120 30-316
1200	1000	300	XM 120 100 30-304	XM 120 100 30-316
1200	1200	300	XM 120 120 30-304	XM 120 120 30-316

Note: Standard lock is swing handle type and made of plastic material. If stainless steel lock type is required, please specify while ordering.

ORDER ALTERNATIVES				
CODE	LOCK	PLAIN DOOR	SYMMETRICAL RAIN CANOPY	WITH GLAND PLATE
XM 60 40 20	X	D	S	R
		GLAZED DOOR	ASYMMETRICAL RAIN CANOPY	
		C	A	

Example of Order Configuration: XM 60 40 20 DSR (Plain door + Symmetrical rain canopy + Gland plate)

XM 60 40 20 AB (Asymmetrical rain canopy + Plinth)

XM 60 40 20 CB (Glazed door + Plinth)

XM 60 40 20 X (Stainless Steel Lock + Gland Plate)

DIMENSIONS

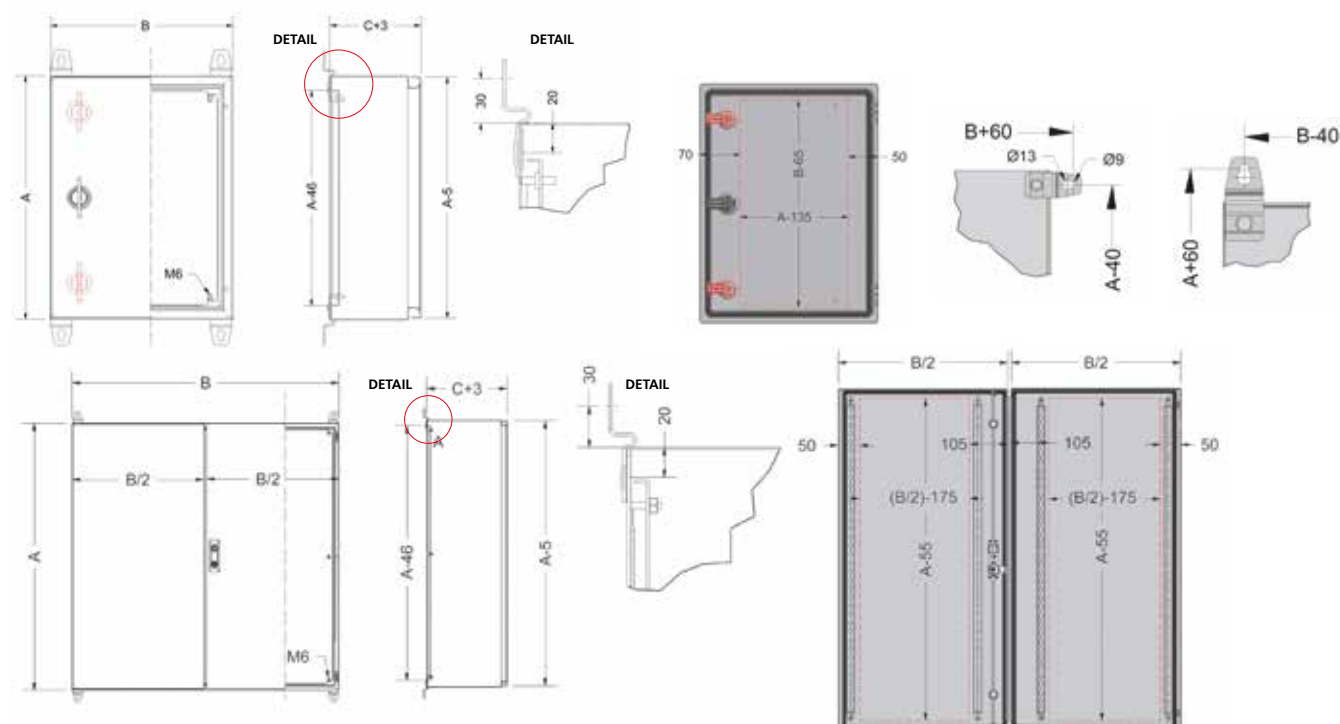

XM SERIES ORDER INFORMATION

XM SERIES STAINLESS STEEL MONOBLOCK FLOOR STANDING ENCLOSURES		
ENCLOSURE RATED HEIGHT (H)	WIDTH (B)	DEPTH (C)
14-1400	400	400
16-1600	500	500
18-1800	600	600
20-2000	700	700
22-2200	800	800

Example of Order Configuration: XM 20 06 04

XM SERIES DIMENSIONS

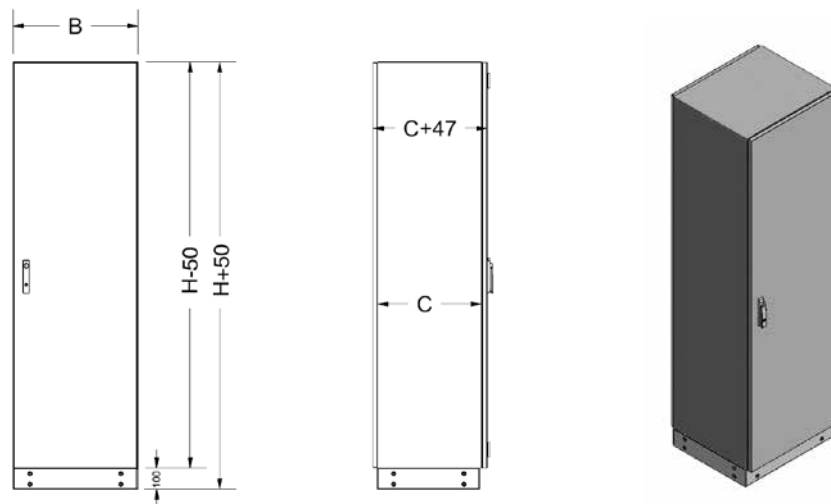

ORDER ALTERNATIVES				
CODE	LOCK	PLAIN DOOR	SYMMETRICAL RAIN CANOPY	PLINTH
XM 60 40 20	X	D	S	B
		GLAZED DOOR	ASYMMETRICAL RAIN CANOPY	
		C	A	

Example of Order Configuration: XM 60 40 20 DSB (Plain Door + Symmetrical Rain Canopy + Plinth)
 XM 60 40 20 AB (Asymmetrical Rain Canopy + Plinth)
 XM 60 40 20 CB (Glazed Door + Plinth)
 XM 60 40 20 XB (Stainless Steel Lock + Plinth)

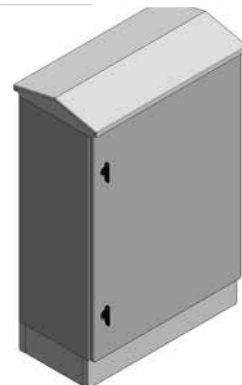

XM SERIES ACCESSORIES

STAINLESS STEEL LOCK TYPES



304 / 316 Swing Handle Lock Type



304 / 316 Stainless Steel Lock Type



Hygenic Lock Type



304 / 316 T - Wing Lock Type

XM BZ PLINTH SET

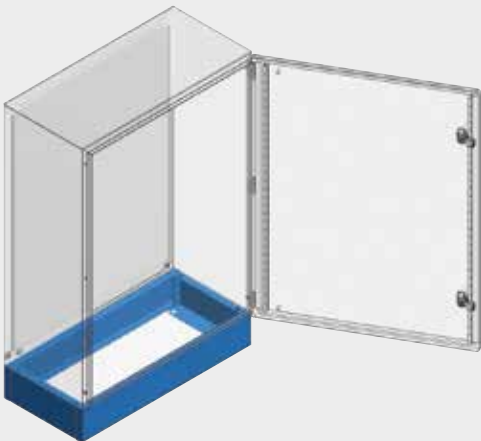

- Supply Contents;
- XM BZ Depth Profile 2 Pcs.
- XM BZ Width Profile 2 Pcs.
- XM BZ Mounting Set 1 Set

Example Configuration: XM 40 30 20 DSB
(Plain Door, Symmetrical Rain Canopy, Plinth)

Please request information from your customer representative before ordering XM BZ Plinth Module.

EG MK FULL HEIGHT MOUNTING PLATES

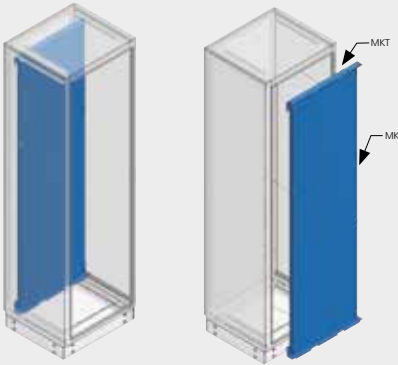

Galvanized sheet material

EM MK FULL HEIGHT MOUNTING PLATES

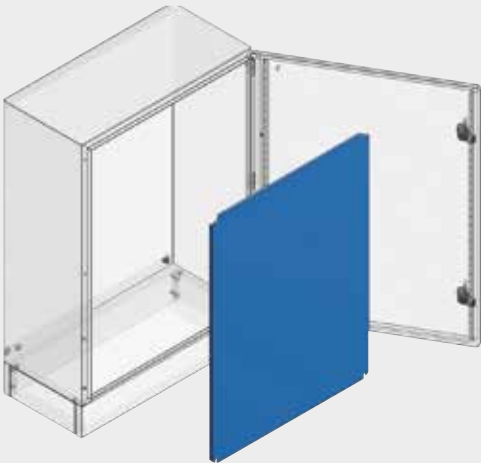

Galvanized sheet material

XM BS BRACKET SET



XM SERIES ACCESSORIES

XM CS STAINLESS STEEL SYMMETRICAL CANOPY

Bracket set can not be used in this application.

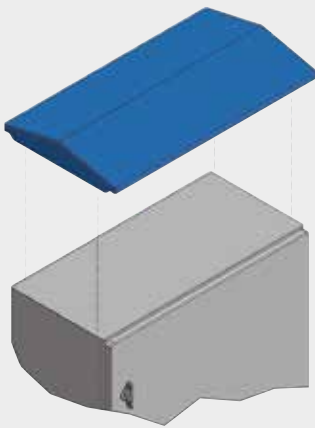

Supply Contents;
XM CM Symmetrical Canopy
Mounting Set

1 Pcs.
1 Set

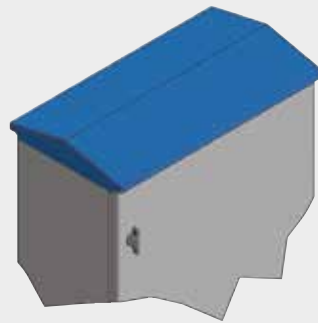

Example Configuration: XM 40 30 20 DS (Plain Door, Symmetrical Canopy)

Please request information from your customer representative before ordering Symmetrical Canopy.

XM CA STAINLESS STEEL ASYMMETRIC CANOPY

XM CM Asymmetric Canopy is applicable for using brackets.

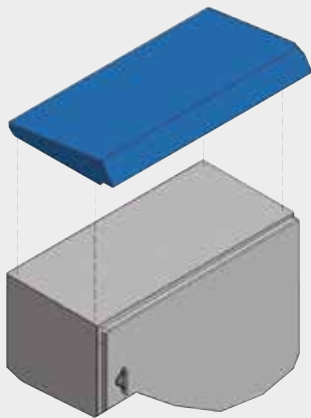

Supply Contents;
XM CM Asymmetrical Canopy
Mounting Set

1 Pcs.
1 Set

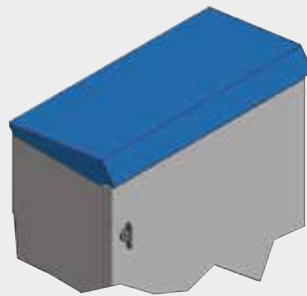

Example Configuration: XM 40 30 20 CA (Glazed Door, Asymmetrical Canopy)

Please request information from your customer representative before ordering Asymmetrical Canopy.

XM OB STAINLESS STEEL FULL HEIGHT COVER PLATE

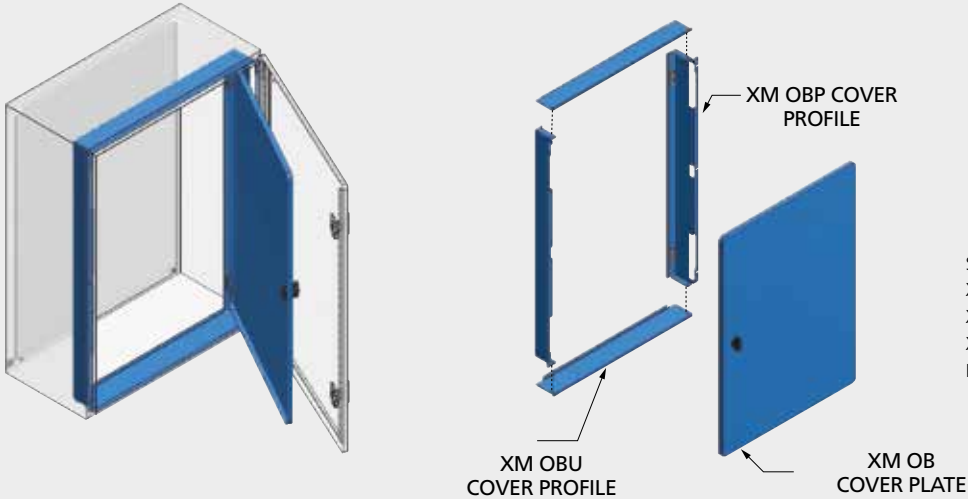

- Supply Contents;
- XM OBP Profile 2 Pcs.
 - XM OBU Profile 2 Pcs.
 - XM OB Cover Plate 1 Pcs.
 - Mounting Set 1 Set

Note: Standard EO OB Cover Plate can also be used.

XM OB STAINLESS STEEL FULL HEIGHT FRONT COVER

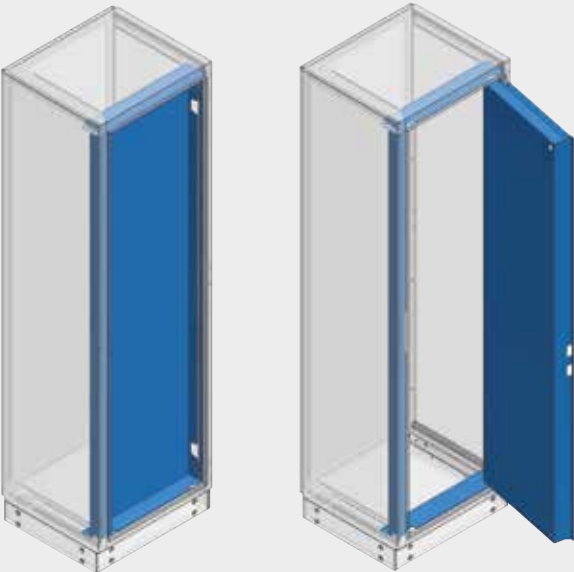

Note: Standard EH DM OB full height painted cover set can also be used.

XM OS STAINLESS STEEL FRONT COVER PLATES

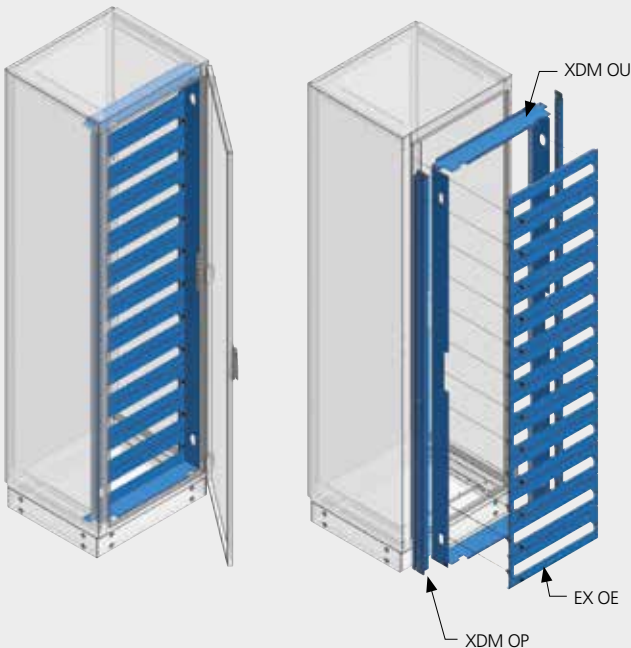

Note: Standard EH DMO painted fixed cover profile set can also be used

XT SERIES OVERVIEW



XT Series Stainless Steel Terminal Boxes

E-Kabin XT Series Terminal Boxes are designed for general purpose electrical applications.

Place of use	: Indoor
Protection class	: IP 66
Type of mounting	: Wall-mounted
Operating temperature	: -5°C, +40°C
Operating relative humidity	: 90% at +20°C 50% at +40°C
Operating environment conditions class	: IE33 but, max. relative humidity %90 and min. temperature -5°C / according to -EN 60721 - 3 - 3 -
Standards	: IEC 62208, IEC 60529, IEC 62262
Material	: 304 grade stainless steel - standard 316 grade stainless steel - optional

XT SERIES CHARACTERISTICS



270° Turn Fastening Screw

Four 270° turn fastening screws provide ease of assembly while maintaining high pressure on the gasket in door fixed position.



IP 66 Protection Class

Polyurethane gasket behind the door does not lose its flexibility and adhesiveness over time. It also provides high protection against dust and water.



Wide Box Opening

Large box opening provides easy access and maximizes usable area.



Functional Mounting Plate

Galvanized steel mounting plate allows to use maximum space inside the box.



Stainless Steel Bracket

Stainless Steel bracket set within standard supply content easily and quickly mounted on the wall. Thanks to 90° swivel feature of the bracket its position can be chosen either horizontally or vertically.

XT SERIES ORDER INFORMATION

XT SERIES DIMENSIONS				
HEIGHT (A)	WIDTH (B)	DEPTH (C)	ORDER CODES (304)	ORDER CODES (316)
200	200	120	XT 20 20-304	XT 20 20-316
200	300	120	XT 20 30-304	XT 20 30-316
200	400	120	XT 20 40-304	XT 20 40-316
300	300	120	XT 30 30-304	XT 30 30-316
300	400	120	XT 30 40-304	XT 30 40-316
400	400	120	XT 40 40-304	XT 40 40-316

Note: Mounting Plate and Bracket Set are in standard supply content.

MOUNTING PLATE

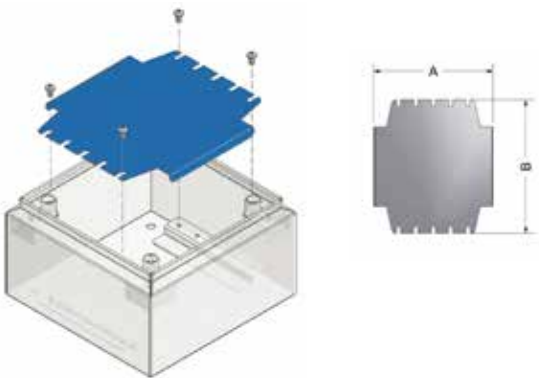

Mounting Plate 1 piece

A DIMENSION	B DIMENSION	ORDER CODE
171	192	ET MK 20 20
171	292	ET MK 20 30
171	392	ET MK 20 40
271	292	ET MK 30 30
371	392	ET MK 30 40

STAINLESS STEEL BRACKET SET

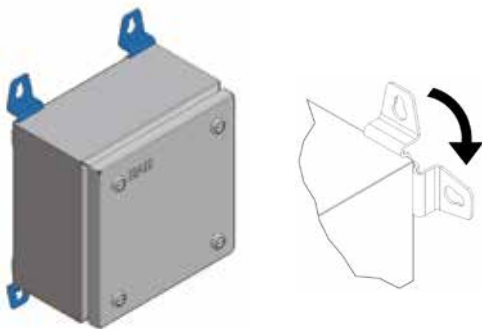

Bracket 4 pcs.

POLE CONNECTION SET

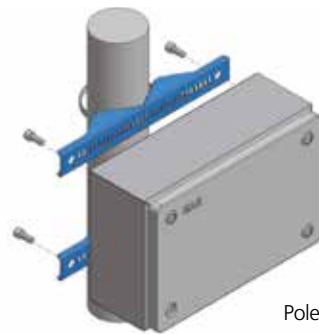

ORDER CODE

XT DB 20
XT DB 30
XT DB 40

Pole Connection Profile 2 sets
Pole Connection Strip 2 sets
Connection Set 1 piece

XT SERIES DIMENSIONS

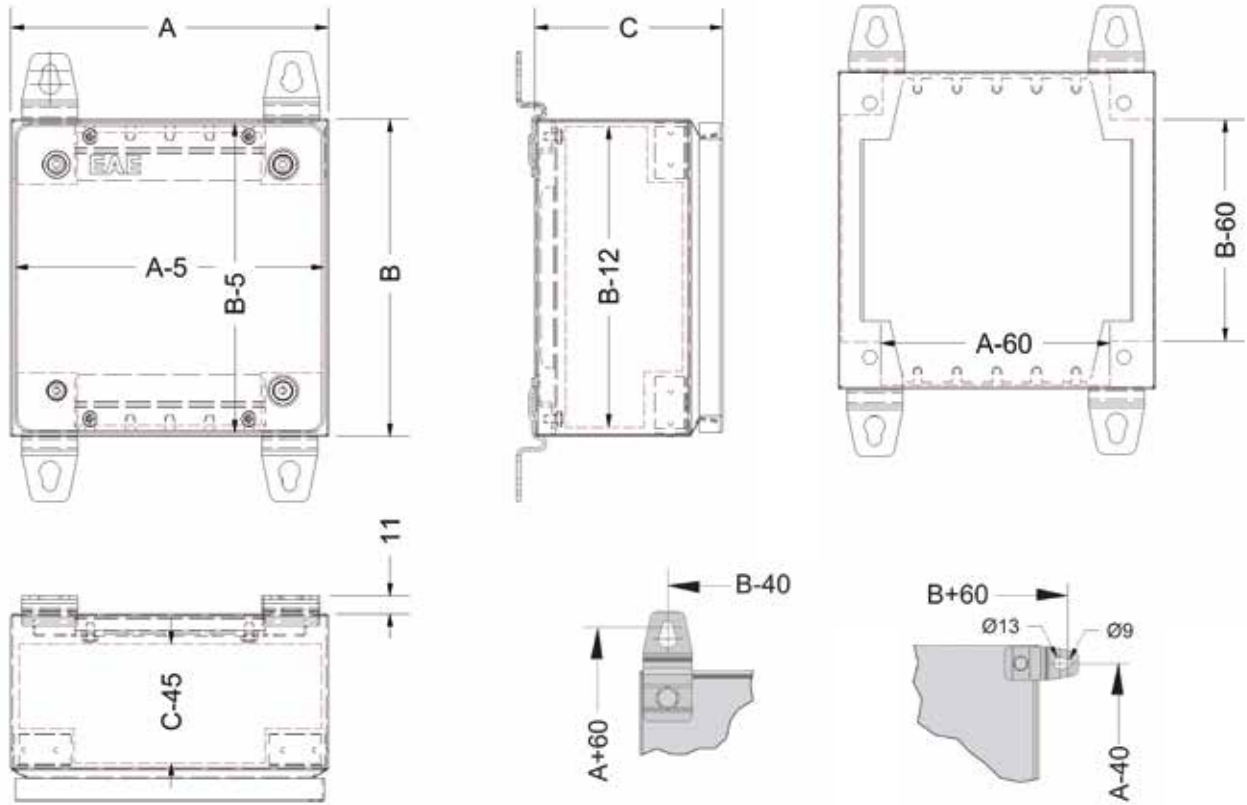

XT SERIES DIMENSIONS

HEIGHT (A)	WIDTH (B)	DEPTH (C)
200	200	120
200	300	120
200	400	120
300	300	120
300	400	120
400	400	120

XK SERIES OVERVIEW



XK Series Stainless Steel Monoblock Console

E-Kabin XK Series Monoblock Consoles are designed for general purpose electrical applications.

Place of use	: Indoor
Protection class	: IP 55
Operating temperature	: -5°C, +40°C
Operating relative humidity	: 90% at +20°C 50% at +40°C
Operating environment conditions class	: IE37 but, max. relative humidity %90 and min. temperature -5°C according to -EN 60721 - 3 - 3 -
Standards	: IEC 61439-1, IEC 62208 IEC 60529, IEC 62262
Material	: 304 grade stainless steel - standard 316 grade stainless steel - optional
Lock Set	: Plastic – Standard Stainless Steel – Optional

XK SERIES CHARACTERISTICS



Rear Door

Easy assembly through rear access from hinged rear door. All hinges of three doors for access - front, back and top - are made of 316 grade stainless steel.

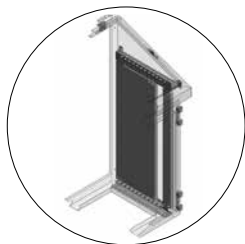

Mounting Possibility at Sides

Mounting rails located at side wall provide mounting possibility of various E-Kabin inner accessories.



IP 55 Protection Class

Polyurethane foam-in-place gasket behind doors does not lose its flexibility and adhesiveness over time. It provides protection against dust and water. Modular bottom cover elements made of the same material as the body and their gaskets provide IP 55 Protection Class.

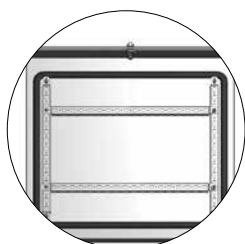

Door Rails

Cable fixing can easily be done by using rails located on the inner side of top door. As standard, there are two profiles on both side fixed through depth. Additional profiles can also be used but should be ordered separately.

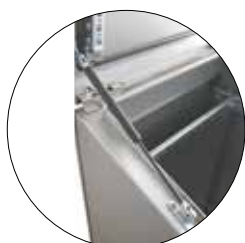

Top Door Piston

Piston is included as standard order content in both sides which enables one to open and close top cover safely.



Double Mounting Plates

Second mounting plate can be used and fixed inside of the console as an additional accessory. In this way, it is possible to obtain two assembly surfaces which can be reached from front and rear.

XK SERIES ORDER INFORMATION

XK SERIES DIMENSIONS				
HEIGHT (A)	WIDTH (B)	DEPTH (C)	ORDER CODES (304)	ORDER CODES (316)
1025	600	400	XK MN 0604-304	XK MN 0604-316
1025	800	400	XK MN 0804-304	XK MN 0804-316
1025	1000	400	XK MN 1004-304	XK MN 1004-316
1025	1200	400	XK MN 1204-304	XK MN 1204-316
1060	600	500	XK MN 0605-304	XK MN 0605-316
1060	800	500	XK MN 0805-304	XK MN 0805-316
1060	1000	500	XK MN 1005-304	XK MN 1005-316
1060	1200	500	XK MN 1205-304	XK MN 1205-316
1095	600	600	XK MN 0606-304	XK MN 0606-316
1095	800	600	XK MN 0806-304	XK MN 0806-316
1095	1000	600	XK MN 1006-304	XK MN 1006-316
1095	1200	600	XK MN 1206-304	XK MN 1206-316

Note: As standard, there are 1 piece mounting plate and 2 pcs. MA mounting profiles fixed through the depth under the top door in each console.

Note: Standard lock and piston component is made of plastic. If locks and/or pistons are required as stainless steel, please specify at your order.

XK SERIES ACCESSORIES

MOUNTING PLATES



EK MN MOUNTING PLATES		
HEIGHT	WIDTH	CODE
698	492	XK MN MK 06
698	692	XK MN MK 08
698	892	XK MN MK 10
698	1092	XK MN MK 12

XK SERIES DIMENSIONS

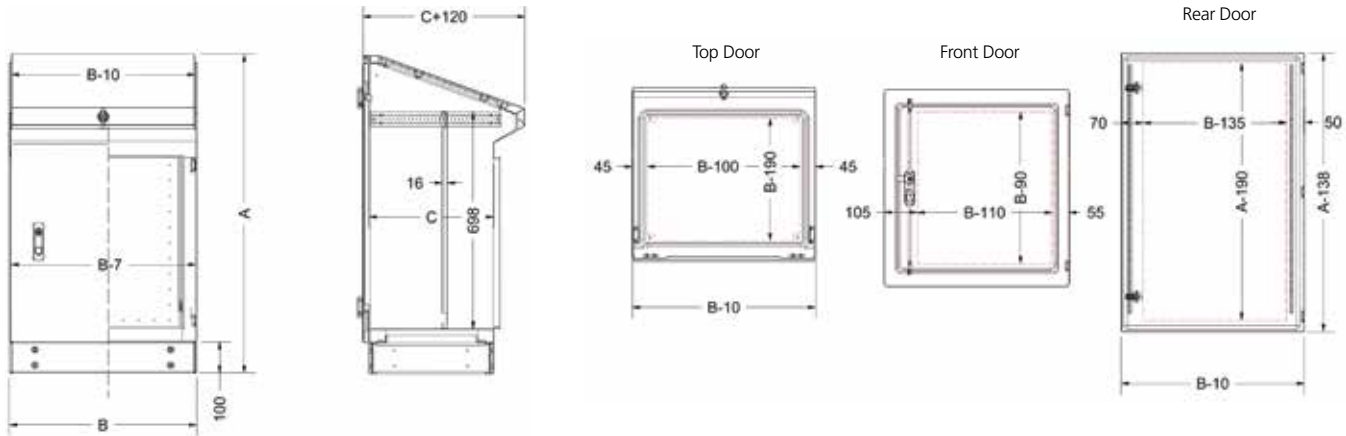
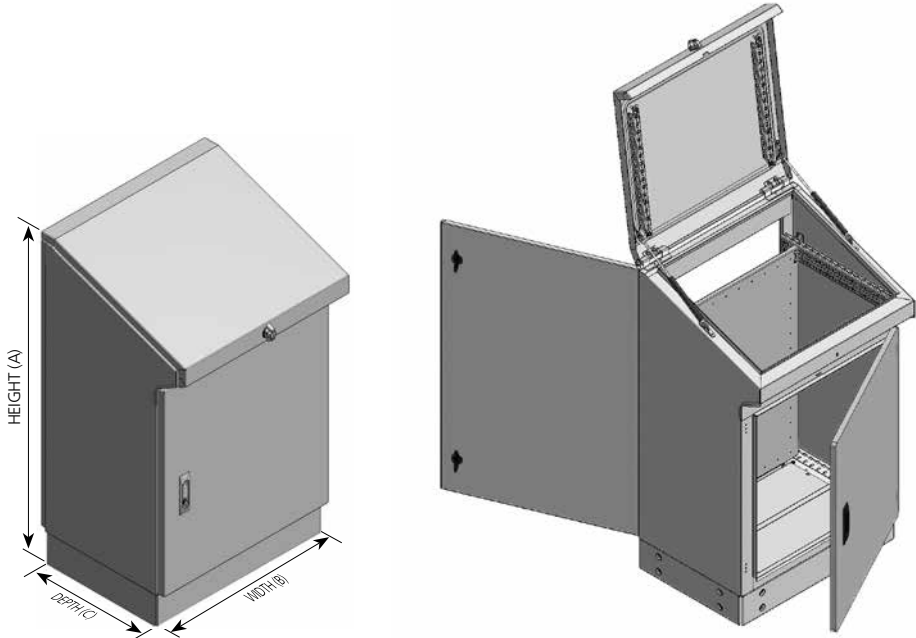

XK SERIES DIMENSIONS					
HEIGHT (A)	WIDTH (B)	DEPTH (C)	HEIGHT (A)	WIDTH (B)	DEPTH (C)
1023	600	400	1023	1000	500
1023	800	400	1023	1200	500
1023	1000	400	1023	600	600
1023	1200	400	1023	800	600
1023	600	500	1023	1000	600
1023	800	500	1023	1200	600

CUSTOM DESIGN



1

Monoblock or modular designs
customised for outdoor applications

2

Different solutions for fixing to the ground

3

Special canopy design - symmetric - asymmetric
and lifting-up solutions

4

Suitable to be used in hygienic environments

5

Optional additional powder coating in any desired
RAL colour or lacquer coating.

STAINLESS STEEL ELECTRICAL ENCLOSURES

It is generally preferred that the electrical enclosures are manufactured from stainless steel material in various industrial applications where corrosion resistance is important. However, there are rules to be considered when selecting and using stainless steel materials.

Stainless Steel Enclosures

Stainless steel is a proven its reliability in various industrial applications as electrical equipment enclosures. In the corrosion resistance of the stainless steel, the environment and its conditions of the application, the grade of steel and the surface treatment have determinant importance.

When the characteristics of stainless steel enclosures are determined for using in a project, by careful consideration of the factors stated here, the required level of corrosion protection and the overall success of the application can be possible.



conditions according to the application area specifications. By this reason, it is not recommended to use 304 grade stainless steel in marine applications without taking special precautions. In cold climate zones, chlorides are used as defrosting chemicals and also, can cause point corrosion on 304 stainless steel surfaces.

In industrial environments, chlorides can be existing in smoke and flying ashes. These are dirt and debris deposits on non-washed, uncleaned surfaces and eventually they may cause point corrosion. Even if the right stainless steel is chosen, corrosive substances condensed in the accumulation of impurities in that way, may cause the protective passive layer on the stainless steel surface to be pierced. In such cases, cleaning is necessary. By this way, self-repairing of stainless steel material can be provided and the stainless steel surfaces can be prevented from condensation of sulfur-dioxide, chloride or ferrous deposits. In another particular attention should be paid not only to the general climatic conditions, but also to the specific micro-climatic conditions where the enclosure is to be mounted. The most obvious example to this, is the negative effect in the settlement areas especially in highways, where salt and chemicals are used as de-icing, which can be carried up to a distance by the vehicles. Likewise, the effects of increased exhaust gas emission by the dense and stopped traffic on the underpass, in the tunnel or at the ticket office, can be evaluated in terms of attracting attention to the micro-climatic conditions.

Stainless steel self-repair feature



The metallic satin finish of the stainless steel makes itself passive, if a suitable environment is provided, i.e. sufficient oxygen and available rich chromium oxidation.

This reaction occurs spontaneously in very short time once the sufficient oxygen contacts on the surface, and the protective layer thus formed becomes thick over time.

The resistance against corrosion on the surface has the ability to repair itself in case of mechanical defection.

Environment and its conditions;

The climate of the area where the application will be, has a great effect on the corrosion resistance of the stainless steel material.

For example, 304 grade stainless steel is resistant to corrosion under a wide range of environment conditions and climate effects, but it is inevitable to experience corrosion in salt and other chloride environments. De facto, 304 grade stainless steel should not be used up to 10 km inside by the sea coast; but the actual length of this distance can be determined by evaluating the climatic

Which grade of stainless steel?

304 grade stainless steel is the most widely used type in different applications where a special corrosion resistance is not required. More harsh environments require the use of 316 qualities which is more expensive grade of stainless steel. However, even for 316 grade stainless steel, chemicals, their concentration and their level of aggressiveness in the environment must be examined,

evaluated and observed in deep detail; because there may be cases where this grade is not sufficient.

304 Grade Stainless Steel **SEA 304-304L / EN 1.4301-1.4303**

Classified as 304 grade by the American Society of Automotive Engineers - SAE, stainless steel contains 18-20% chromium and 8-10.5% nickel. The 304 grade sometimes referred to as '18 -8 ', is widely used as standard stainless steel grade in different industrial applications. The most common application where the use of 304 quality stainless steel is inconvenient, is the outdoor applications in the coastal areas where the salt is deposited on the surfaces by flying.

In the food and beverage industry, it is necessary for the enclosures to be washed frequently without worrying about rusting. 304 grade stainless steel is used extensively here. Due to its high resistance to various acids found in meat, milk, fruits and vegetables, 304 grade stainless steel has become the ideal raw material for control and control equipment enclosures of machines used in food and beverage processes. Nevertheless, a stronger stainless steel grade may be required, if the environment has excessive chloride usage, or cleaning procedures require high corrosion resistance solvents.

The use of 304 grade stainless steel may be sufficient in a majority of waste treatment and clean water treatment plants. However, in some clean water treatment plants, chlorine gas is used as a disinfectant and sulfur dioxide is used to remove the residues of used chlorine. When the nature of the environment with high humidity and the corrosive effect of these gases are combined together, the capabilities of 304 grade stainless steel are exceeded. Some municipalities put efforts to use less chemicals with environment friendly approaches and apply ultraviolet treatment for water treatment. 304 quality stainless steel can be used, due to no chemical usage in such facilities.

316 Grade Stainless Steel **SEA 316-316L / EN 1.4401-1.4404**

The second most widely used grade of stainless steel is 316 when the limits of 304 are reached. In general, 316 quality stainless steel, which is 25-35% more expensive, has a higher nickel content and an additive molybdenum content of 2-3%. Molybdenum additive provides increase of corrosion resistance especially against chlorides. The rate of chloride contained in water is the most determinant factor in the selection of stainless steel enclosure material for water treatment plants. 304 grade stainless steel is able to withstand against the corrosive effect of water containing up to 100 ppm of chloride. On the contrary, in the 316 grade stainless steel material,



this limit is up to 1000 ppm of chloride. In addition to chlorides, there are other substances that affect the corrosive behavior of the water. Especially, attention should be paid to halides such as bromides or iodides which are not chlorides. Another important factor is the presence of water oxidizers (e.g. ozone); the risk of point corrosion is also increasing as long as water oxidizing power increases. In such some cases, 316 grade stainless steel is also insufficient.

316 grade stainless steel commonly known as the marine standard, cannot withstand to be presented in continuous saline water (equivalent to 19,000 ppm chlorine). However, it can be used in overwater applications such as temporary and short-term salt spray applications. It should not be forgotten to take various precautions for the application areas with narrow and closed low airflow a difficult harsh environment conditions with low pH or high temperature. 316 grade stainless steel is generally considered as an adequate enclosure for marine applications such as ships and oil platforms and even for salt mines. Essentially, the stainless steel grade is 316 which should be used mainly in corrosive environments where high chloride levels are present.

316 grade stainless steel should be preferred because of having high chloride resistance in food processing plants using excessive acidic chemicals and concentrated chloride salts. 316 grade stainless steel having considerable degree of resistance against sulfuric acid solutions (<10%) and sulfur-containing gases, is used as the raw materials for the enclosures used in industries where they are frequently found. For example, 316 grade stainless steel is used in the paper industry. Similarly, in other industries such as vulcanization process for the rubber or gun powder manufacturing, it is also widely used.

Nitric and hydrochloric acid

As a general rule, 316 grade stainless steel enclosures are more resistant to aggressive chemical environments than



304 grade. Nitric acid is at the top of special cases which does not suit this rule. Nitric acid is especially used in fertilizer production, pharmaceutical industry and explosive production; also, it can be used in synthetic yarn and polymer manufacturing or in water treatment plants.

All stainless steel grades have a slight resistance to nitric acid, but in industries where the use of nitric acid is widespread, 304 grade stainless steel should be preferred due to its high resistance against this substance. In this case, the self-passive ability of the stainless steel is enhanced by the strong oxidizing effect of nitric acid and the corrosion resistance of the stainless steel is increased.

It is important to consider that neither the 304 grade nor the 316 grade stainless steel will be able to withstand against the chemical corrosion caused by hydrochloric acid. This acid destroys the passive surface and leaves the metal vulnerable.

Swimming pool environments

The swimming pool atmosphere is generally characterized by a relative humidity approximately 60-70% together with chlorine and chlorine compounds relatively high levels. The original "pool smell" is existent due to these. These substances can be spread to the entire space as both steam



and aerosol. In addition to sodium chloride, relatively high amounts of calcium and magnesium chloride are found in many applications. Typical values are 2-5% for the chloride ratio and 3-4 for the pH value. The high relative humidity rate fluctuates by depending on the intensity of swimming activity, the temperature changes during the day and resulting in the accumulation of deposits at various locations with the switched off air conditioning system in the nights. The evaporation of chloride-containing liquids and the increase of chloride concentration in the contact zones considerably increase the likelihood of corrosion.

It is necessary to pay special attention to the selection of the right material in swimming pool applications. Especially, attention should be paid to the selection of materials for enclosures placed in closed areas such as machine rooms of pools. Special precautions such as micro climate air quality, should be taken in these applications. It is obvious that the selection of 316 grade stainless steel will not sufficient alone in the presence of oxidizing substances such as ozone or where disinfectant chemicals are stored. In this case application of lacquer coating or 316 quality stainless steel or both is required.

Surface treatment

Grinding is common surface treatment for stainless steel enclosures used in industrial applications. The protective film as the purpose of masking, adhered on the outer surfaces of the enclosures is kept to the very last of the manufacturing steps, after removing the film and the possible adhesive residues are cleaned with special chemicals, the enclosure is packed with an air-permeable material before last packaging.

In addition to the surface treatment quality, the direction of grinding of the stainless steel surface is also important in terms of corrosion resistance. The vertically oriented grinding allows cleaning to be done easily and in case of outdoor applications, rain water can flow down itself with help of gravity. Some stainless steel enclosures can be painted. Especially, it is known that outdoor stainless steel enclosures exposed to intense solar radiation can be 10 degrees cooler, if they are painted with a light color. It is also possible to consider the paint as an additional layer of protection for extremely corrosive environments. Stainless steel can be painted by using standard paint process.

Hygienic applications

Stainless steel enclosures are also preferred for their superior hygienic features in addition to their corrosion resistance. It is more difficult to stick and reproduce for bacteria and microbes on stainless steel surfaces (assuming to have appropriate surface smoothness). The smooth and though surface of the stainless steel allows for easier and more effective cleaning.

Precautions for storage and construction site environment

In order to ensure that the surface qualities of stainless steel enclosures are also protected under storage and site conditions, some precautions might be needed to be taken in addition to the manufacturer's precautions such as product packaging.

Water which may accumulate during storage and transport, especially under heat shrinkage or under the plastic packaging of the stretch-film construction, may cause corrosion. This is the case when the packaged product is left in a humid environment for a long time. Strong acids (chloride based) which can be used for cleaning after ground work, especially stone or ceramic laying in new buildings, should be prevented from getting in contact with stainless steel surfaces. Any cleaning or rinsing fluid must not be interacted with the surrounding metals.

During storage, transfer, positioning and assembling in construction site environment, contamination of stainless steel enclosures' surfaces with carbon steel or iron must be avoided. For example, metal machining, grinding or welding around stainless steel enclosures should be avoided or precautions should be taken. Carbon steel metal burrs or slag splashing on the stainless steel surfaces will cause corrosion of splinters.



Cleaning before delivery

The stainless steel electrical enclosures manufactured by EAE, are delivered in an air-permeable package material, after the protective film is stripped and the surface is cleaned with flying chemicals which have protective features for stainless steel. Before the final delivery against the contamination, it is necessary to clean the surface deflections which may be occurred in the workshop environment or the construction site environment. Mortars and cement particles can be cleaned with 10-15% phosphoric acid. The solution should be applied hot onto the surface, subsequently, neutralized by the ammonia solution, finally rinsed with water purified from the minerals. Cleaning products manufacturers offer some special products for this type of cleaning. The superficial

light stains can be removed by gentle cleaning creams and polishing pastes which are available in the market. These cleaning products contain substances that can penetrate the surface together with calcium carbonate. Household cleaners are also based on lemon acid and suitable for cleaning.

Grinding powders containing iron adhering to the surface in a short time ago, should be cleaned with saturated solutions of oxalic acids. Firstly, it must be applied to the surface without pressing hardy with a soft cotton cloth or cotton-based polishing pad and waited for a few minutes. Thus, as a rule, it is ensured that the particles are separated from the surface without scratches and damages on the surface. Moderate level rust stains are cleaned using cleaning products containing phosphoric acid. Careful cleaning is done without damaging the surface and changing color. Alternatively, small amounts of iron particles treated on the surface are successfully cleaned with slenderized nitric acid. It is only possible to clean the surface treated with rust thoroughly with acid processing and / or passivation to be done professionally. The acid cleaning process should be considered as a thin layer removal from the surface. For this, a mixture of nitric acid and hydrofluoric acid is generally used. Passivation process is a controlled and accelerated reconstitution of the impaired passive layer on the surface in the nitric acid environment. However, first of all, the oil and organic soils on the surface must be cleaned.

Maintenance

For all stainless steel applications, periodic surface maintenance should be planned and applied during operation.

304 and 316 grades raw material discrimination test:



304

316

A fine liquid from Monil 304-316 separator solution is dropped on the surface (under room temperature). 20-25 minutes to be waited. The colour of drop is watched. On the tested surface, in 5 minutes, yellow-green-brown color changes in sequence as the proof of 316 grade stainless steel. For 316L grade stainless steel, more than 5 minutes to be waited.

**Some of the most important environmental pollutants in different environments
(ISO 9223: 2012 Annex B, IEC 60721-3-3: 2002, IEC 60721-2-5: 1991)**

Environmental pollutant	ISO 9223 Condensation/ Residue (annual mean value) ($\mu\text{g} / \text{m}^3$)	IEC 60721-3-3		ISO 9223	ISO 9223 Sources of Residue
		Reference Value ($\mu\text{g}/\text{m}^3$)	Class	Environment	
SO ₂	2-15	10		rural	The main reasons of SO ₂ are the usage of coal and fuel with the emissions of industrial plants.
	5-100	100 max.	3C1L 3C1	urban	
	50-400	300	3C2	industrial	
NO ₂	2-25	100 max.	3C1L	rural	The main reason of SO ₂ is traffic.
	20-150		3C1	urban	
HNO ₃	0,1-0,7			rural	HNO ₃ is in correlation with NO ₂ . High concentrated NO ₂ organic compound and UV light concentration will increase.
	0,5-4			industrial	
O ₃	< 10	10 max.	3C1L 3C1		O ₃ occurs with the interaction of sunlight, oxygen and environmental pollutants in the atmosphere. Concentrations are higher in dirty rural atmosphere but, in urban areas with high traffic is lower.
	10 < X < 20	10 max.	3C1L		
	20-90	50	3C2		
H ₂ S	1-5	10 max.	3C1L 3C1	in normal	There are some natural resources such as swamps and volcanic activities. Pulp, paper industry and agriculture produce the highest concentrations.
	20-250	100	3C2	industrial & animal shelters	
Cl ₂	0,1			in normal	Main sources are the emissions of paper and pulp industries.
	20'ye kadar			some industrial plants	
Cl	0,1-200	10 max.	3C1L 3C1		The main sources are the defrosting of ice in the oceans and the roads. Depending on the geographical location - in the marine environment.
		100	3C2		
	300-1500	600	3C4		
NH ₃	< 20			low concentration in normal	The emissions sourced from food production and fertilizing industry in agriculture provide the highest average values.
	< 300	300 max.	3C1L 3C1	close to source	
	300 to 1000			close to source	
	1000 to 3000	1000	3C2	close to source	
Particles PM ₁₀	10-25			rural	Largely, ineffective components
	30-70			urban	High density traffic, corrosive ingredients
					industrial

Note: This table indicates the general limits of the concentrations of pollutants. Actual ranges can be varied in some certain regions of the world depending on the level of industrialization and the implementation of precautions for reducing pollution. (legal precautions, exhaust emission technologies, etc.)

TEST CERTIFICATE

Issued to: EAE Elektrotechnik San. ve Tic. A.S.
Ikitelli Organize Sanayi Bolgesi,
Ziya Gokalp Mh. Eski Turgut Ozal Cd. No:20
34490 Basaksehir - Istanbul
Turkey

For the product: Empty enclosure for low-voltage switchgear and controlgear assemblies

Trade name: EAE

Type/Model: E-Kabin D / S / H / X / L / E / M / O / T / K Series

Ratings: IP67 (T Series), IP66 (M / O Series), IP55 (E / S / D / L / H / K Series),
IP41 / IP30 (S / D / L Series (natural ventilated)),
IP30 (E Series with safety glass door); IK 10;
indoor (D / S / L / E / O / K Series), outdoor (H Series), indoor/outdoor (M / T Series)
For more details see annex

Manufactured by: EAE Elektrotechnik San. Ve Tic. A.S.
Ikitelli Organize Sanayi Bolgesi,
Ziya Gokalp Mh. Eski Turgut Ozal Cd. No:20
34490 Basaksehir - Istanbul
Turkey

Subject: Type test

Requirements: IEC 62208:2011
Clauses 9.3 - 9.9 and 9.11 - 9.14

Remarks: Date of performance of tests: 2009 - 2014 (see general notes on tests in the report)

This Test Certificate is granted on account of an examination by DEKRA, the results of which are laid down in report no. 2171524.01-INC, issued on 16 February 2015.

The examination has been carried out on one single specimen of the product, submitted by the manufacturer. The Attestation does not include an assessment of the manufacturer's production. Conformity of his production with the specimen tested by DEKRA is not the responsibility of DEKRA.

Arnhem, 16 February 2015

Number: 2171524.100

DEKRA Certification B.V.



F.S. Strikwerda
Certification Manager

Integral publication of this certificate and adjoining reports is allowed

DEKRA Certification B.V. Meander 1051, 6825 MJ Arnhem P.O. Box 5185, 6802 ED Arnhem, The Netherlands
T +31 88 96 83000 F +31 88 96 83100 www.dekra-certification.com Company registration 09085396



ELEKTROTEKNİK

www.eaelektroteknik.com

EAE Elektroteknik A.Ş.
Ikitelli Organize Sanayi Bolgesi
Eski Turgut Ozal Caddesi
Ziya Gokalp Mahallesi No: 20
34490 Basaksehir - Istanbul / TURKEY
Phone : +90 (212) 549 26 39 (pbx)
Fax : +90 (212) 549 37 91
E-mail : ekabin@eae.com.tr
Web : www.eaelektroteknik.com